

SkyLine ProS Electric Combi Oven 16 trays 600x400mm, Bakery

ITEM # _____

MODEL # _____

NAME # _____

SIS # _____

AIA # _____

237304 (ECO201K3A3B)

SkyLine ProS Combi Boilerless Oven with touch screen control, 16 600x400mm, electric, 2 cooking modes (recipe program, manual), automatic cleaning, 3-glass door, for bakery/pastry, pitch 80mm

Short Form Specification

Item No.

Combi oven with high resolution full touch screen interface, multilanguage.

- Boilerless steaming function to add and retain moisture.
- OptiFlow air distribution system to achieve maximum performance with 7 fan speed levels.
- SkyClean: Automatic and built-in self cleaning system. 4 automatic cycles (short, medium, intensive, rinse) and green functions to save energy, water, detergent and rinse aid.
- Cooking modes: Programs (a maximum of 1000 recipes can be stored and organized in 16 different categories); Manual; EcoDelta cooking cycle.
- Special functions: MultiTimer cooking, Plan-n-Save to cut running costs, Make-it-Mine to customize interface, SkyHub to customize homepage, agenda MyPlanner, automatic backup mode to avoid downtime.
- USB port to download HACCP data, programs and settings
- Connectivity for real time access, remote software update, HACCP, recipe and energy management (optional)
- Single sensor core temperature probe.
- Triple-glass door with double LED lights line.
- Stainless steel construction throughout.
- Supplied with n.1 pastry tray rack 600x400 mm, 80 mm pitch..

Main Features

- Boilerless steaming function to add and retain moisture for high quality, consistent cooking results.
- Dry hot convection cycle (max 300 °C) ideal for low humidity cooking. Automatic moistener (11 settings) for boiler-less steam generation.
- Short cleaning cycle: optimized cleaning cycle with a duration of just 33 minutes, improving efficiency and reducing downtime.
- 6-point multi sensor core temperature probe for maximum precision and food safety (optional accessory).
- SkyClean: Automatic and built-in self cleaning system with 4 automatic cycles (short, medium, intensive, rinse).
- EcoDelta cooking: cooking with food probe maintaining preset temperature difference between the core of the food and the cooking chamber.
- Programs mode: a maximum of 1000 recipes can be stored in the oven's memory, to recreate the exact same recipe at any time. The recipes can be grouped in 16 different categories to better organize the menu. 16-step cooking programs also available.
- MultiTimer function to manage up to 60 different cooking cycles at the same time, improving flexibility and ensuring excellent cooking results. Can be saved up to 200 MultiTimer programs.
- OptiFlow air distribution system to achieve maximum performance in chilling/heating evenness and temperature control thanks to a special design of the chamber.
- Fan with 7 speed levels from 300 to 1500 RPM and reverse rotation for optimal evenness. Fan stops in less than 5 seconds when door is opened.
- Single sensor core temperature probe included.
- Automatic fast cool down and pre-heat function.
- Back-up mode with self-diagnosis is automatically activated if a failure occurs to avoid downtime.
- Electrolux Professional recommends the use of treated water to guarantee optimal cooking results and extend the life of the appliance. Check local water condition to select the appropriate water filter. More info available on the website.

Construction

- Triple thermo-glazed door with 2 hinged inside panels for easy cleaning and double LED lights line.
- Hygienic internal chamber with all rounded corners for easy cleaning.
- 304 AISI stainless steel construction throughout.
- Front access to control board for easy service.
- IPX5 spray water protection certification for easy cleaning.

User Interface & Data Management

- Connectivity for remote real time access, easy HACCP management, equipment uptime increase, consumption tracking and energy management (requires optional accessory).
- High resolution full touch screen interface

APPROVAL: _____

(translated in more than 30 languages) - color-blind friendly panel.

- With SkyDuo the Oven and the Blast Chiller are connected to each other and communicate in order to guide the user through the cook&chill process optimizing time and efficiency (requires optional accessory).
- Pictures upload for full customization of cooking cycles.
- Make-it-mine feature to allow full personalization or locking of the user interface.
- SkyHub lets the user group the favorite functions in the homepage for immediate access.
- MyPlanner works as an agenda where the user can plan the daily work and receive personalized alerts for each task.
- USB port to download HACCP data, share cooking programs and configurations. USB port also allows to plug-in sous-vide probe (optional accessory).
- Trainings and guidances supporting materials easily accessible by scanning QR-Code with any mobile device.
- Automatic consumption visualization at the end of the cycle.

Sustainability

- Human centered design with 4-star certification for ergonomics and usability.
- Wing-shaped handle with ergonomic design and hands-free opening with the elbow, making managing trays simpler. Protected by registered design (EM003143551 and related family).
- The outer cardboard packaging is made from 70% recycled materials and FSC*-certified paper, printed with eco-friendly, water-based ink to support sustainability and environmental responsibility.

<i>(*Forest Stewardship Council is the world's leading organization for sustainable forest management).</i>

- Triple-glass door minimize your energy loss.*

*<i>Approx. -10% of idle energy consumption in convection based on test in compliance with ASTM Standard F2861-20</i>

- Save energy, water, detergent and rinse aid with SkyClean green functions.
- C22 and C25 detergents are formulated without phosphates and phosphorus (C25 is also maleic acid-free), making them safe for both the environment and human health.
- Reduced powerfunction for customized slow cooking cycles.
- Plan-n-Save function organizes the cooking sequence of the chosen cycles optimizing the work in the kitchen from a time and energy efficiency point of view.

Included Accessories

- 1 of Bakery/pastry trolley with rack holding 600x400mm grids for 20 GN 1/1 oven and blast chiller freezer, 80mm pitch (16 runners) PNC 922761

Optional Accessories

- Water filter with cartridge and flow meter for high steam usage (combi used mainly in steaming mode) PNC 920003
- Water filter with cartridge and flow meter for medium steam usage PNC 920005
- Pair of AISI 304 stainless steel grids, GN 1/1 PNC 922017
- Pair of grids for whole chicken (8 per grid - 1,2kg each), GN 1/1 PNC 922036
- AISI 304 stainless steel grid, GN 1/1 PNC 922062

- Grid for whole chicken (4 per grid - 1,2kg each), GN 1/2 PNC 922086
- External side spray unit (needs to be mounted outside and includes support to be mounted on the oven) PNC 922171
- Baking tray for 5 baguettes in perforated aluminum with silicon coating, 400x600x38mm PNC 922189
- Baking tray with 4 edges in perforated aluminum, 400x600x20mm PNC 922190
- Baking tray with 4 edges in aluminum, 400x600x20mm PNC 922191
- Pair of frying baskets PNC 922239
- AISI 304 stainless steel bakery/pastry grid 400x600mm PNC 922264
- Grid for whole chicken (8 per grid - 1,2kg each), GN 1/1 PNC 922266
- USB probe for sous-vide cooking PNC 922281
- Grease collection tray, GN 1/1, H=100 mm PNC 922321
- Kit universal skewer rack and 4 long skewers for Lengthwise ovens PNC 922324
- Universal skewer rack PNC 922326
- 4 long skewers PNC 922327
- Grease collection tray, GN 1/1, H=40 mm PNC 922329
- Volcano Smoker for lengthwise and crosswise oven PNC 922338
- Multipurpose hook PNC 922348
- Grid for whole duck (8 per grid - 1,8kg each), GN 1/1 PNC 922362
- Thermal cover for 20 GN 1/1 oven and blast chiller freezer PNC 922365
- Wall mounted detergent tank holder PNC 922386
- USB single point probe PNC 922390
- IoT module for OnE Connected (Combi Ovens, Blast chiller/freezers, Rack Type DW) and SkyDuo (one IoT board per appliance - to connect oven to blast chiller for Cook&Chill process). PNC 922421
- Connectivity router (WiFi and LAN) PNC 922435
- Elevating kit with trolley height extension for 20 GN 1/1 oven PNC 922446
- External connection kit for liquid detergent and rinse aid PNC 922618
- Dehydration tray, GN 1/1, H=20mm PNC 922651
- Flat dehydration tray, GN 1/1 PNC 922652
- Heat shield for 20 GN 1/1 oven PNC 922659
- Trolley with tray rack, 15 GN 1/1, 84mm pitch PNC 922683
- Kit to fix oven to the wall PNC 922687
- 4 flanged feet for 20 GN , 2", 100-130mm PNC 922707
- Mesh grilling grid, GN 1/1 PNC 922713
- Probe holder for liquids PNC 922714
- Levelling entry ramp for 20 GN 1/1 oven PNC 922715
- Condensation hood with fan for 20 GN 1/1 electric oven PNC 922725
- Exhaust hood with fan for 20 GN 1/1 oven PNC 922730
- Exhaust hood without fan for 20 1/1GN oven PNC 922735

- | | | | | | |
|---|------------|--------------------------|--|------------|--------------------------|
| • Stainless steel drain kit for 20 GN oven, dia=50mm | PNC 922738 | <input type="checkbox"/> | • C25 Rinse & Descale Tabs, phosphate-free, phosphorous-free, maleic acid-free, 50 tabs bucket | PNC 0S2394 | <input type="checkbox"/> |
| • Plastic drain kit for 20 GN oven, dia=50mm | PNC 922739 | <input type="checkbox"/> | • C22 Cleaning Tabs, phosphate-free, phosphorous-free, 100 bags bucket | PNC 0S2395 | <input type="checkbox"/> |
| • Holder for trolley handle (when trolley is in the oven) for 20 GN oven | PNC 922743 | <input type="checkbox"/> | | | |
| • Tray for traditional static cooking, H=100mm | PNC 922746 | <input type="checkbox"/> | | | |
| • Double-face griddle, one side ribbed and one side smooth, 400x600mm | PNC 922747 | <input type="checkbox"/> | | | |
| • Hood Hopper to directly connect the Hood to the centralized ventilation system, for Standard Hoods (with fan motor) and Hoods without fan motor | PNC 922751 | <input type="checkbox"/> | | | |
| • Trolley with tray rack, 20 GN 1/1, 63mm pitch | PNC 922753 | <input type="checkbox"/> | | | |
| • Trolley with tray rack, 16 GN 1/1, 80mm pitch | PNC 922754 | <input type="checkbox"/> | | | |
| • Banquet trolley with rack holding 54 plates for 20 GN 1/1 oven and blast chiller freezer, 74mm pitch | PNC 922756 | <input type="checkbox"/> | | | |
| • Bakery/pastry trolley with rack holding 600x400mm grids for 20 GN 1/1 oven and blast chiller freezer, 80mm pitch (16 runners) | PNC 922761 | <input type="checkbox"/> | | | |
| • Banquet trolley with rack holding 45 plates for 20 GN 1/1 oven and blast chiller freezer, 90mm pitch | PNC 922763 | <input type="checkbox"/> | | | |
| • Kit compatibility for aos/easyline trolley (produced till 2019) with SkyLine/Magistar 20 GN 1/1 combi oven | PNC 922769 | <input type="checkbox"/> | | | |
| • Kit compatibility for aos/easyline 20 GN oven with SkyLine/Magistar trolleys | PNC 922771 | <input type="checkbox"/> | | | |
| • Water inlet pressure reducer | PNC 922773 | <input type="checkbox"/> | | | |
| • Extension for condensation tube, 37cm | PNC 922776 | <input type="checkbox"/> | | | |
| • Kit for installation of electric power peak management system for 20 GN Oven | PNC 922778 | <input type="checkbox"/> | | | |
| • Non-stick universal pan, GN 1/1, H=40mm | PNC 925001 | <input type="checkbox"/> | | | |
| • Non-stick universal pan, GN 1/1, H=60mm | PNC 925002 | <input type="checkbox"/> | | | |
| • Double-face griddle, one side ribbed and one side smooth, GN 1/1 | PNC 925003 | <input type="checkbox"/> | | | |
| • Aluminum grill, GN 1/1 | PNC 925004 | <input type="checkbox"/> | | | |
| • Frying pan for 8 eggs, pancakes, hamburgers, GN 1/1 | PNC 925005 | <input type="checkbox"/> | | | |
| • Flat baking tray with 2 edges, GN 1/1 | PNC 925006 | <input type="checkbox"/> | | | |
| • Baking tray for 4 baguettes, GN 1/1 | PNC 925007 | <input type="checkbox"/> | | | |
| • Potato baker for 28 potatoes, GN 1/1 | PNC 925008 | <input type="checkbox"/> | | | |
| • Non-stick universal pan, GN 1/2, H=20mm | PNC 925009 | <input type="checkbox"/> | | | |
| • Non-stick universal pan, GN 1/2, H=40mm | PNC 925010 | <input type="checkbox"/> | | | |
| • Non-stick universal pan, GN 1/2, H=60mm | PNC 925011 | <input type="checkbox"/> | | | |
| • Kit of 6 non-stick universal pans, GN 1/1, H=20mm | PNC 925012 | <input type="checkbox"/> | | | |
| • Kit of 6 non-stick universal pans, GN 1/1, H=40mm | PNC 925013 | <input type="checkbox"/> | | | |
| • Kit of 6 non-stick universal pan GN 1/1, H=60mm | PNC 925014 | <input type="checkbox"/> | | | |

Recommended Detergents



SkyLine ProS
 Electric Combi Oven 16 trays 600x400mm, Bakery

The company reserves the right to make modifications to the products without prior notice. All information correct at time of printing.

Front

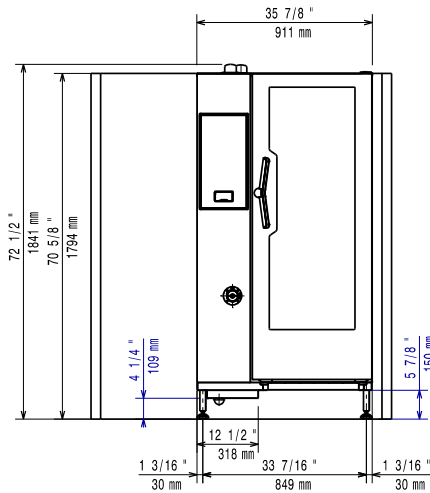

Side

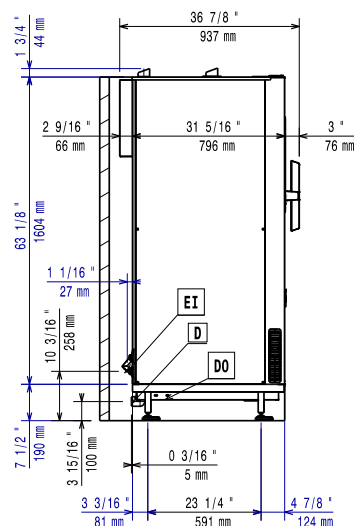

CWI1 = Cold Water inlet 1 (cleaning) EI = Electrical inlet (power)
 CWI2 = Cold Water Inlet 2 (steam generator)
 D = Drain
 DO = Overflow drain pipe

Top

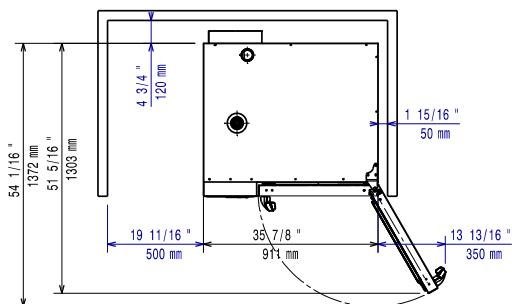

Electric

Supply voltage:	380-415 V/3N ph/50-60 Hz
Electrical power, max:	40.4 kW
Electrical power, default:	37.7 kW

Water:

Inlet water temperature, max:	30 °C
Inlet water pipe size (CWI1, CWI2):	3/4"
Pressure, min-max:	1-6 bar
Chlorides:	<10 ppm
Conductivity:	>50 µS/cm
Drain "D":	50mm

Capacity:

Trays type:	16 (400x600 mm)
Max load capacity:	100 kg

Key Information:

Door hinges:	Right Side
External dimensions, Width:	911 mm
External dimensions, Depth:	864 mm
External dimensions, Height:	1794 mm
Weight:	289 kg
Net weight:	262 kg
Shipping weight:	289 kg
Shipping volume:	2.11 m ³

ISO Certificates

ISO Standards:	ISO 9001; ISO 14001; ISO 45001; ISO 50001
----------------	---